

Developmental Parameters in Family Therapy Training: The appropriation process of the therapist's family history.

Anne Chouhy¹

Abstract: The therapist is his own therapeutical instrument. In order not to be invaded by the emotions that the therapeutical system evokes and amplifies from his family history, he must go through a process of cognitive and emotional learning, which necessarily depends on the recognition of his own family history. The article explores this appropriation process of the therapist's family history and describes firstly, how in the context of supervision and starting from structural similarities or isomorphisms between the consulting family and the therapist's family of origin, the latter recovers significant aspects of his family history. Secondly, how insofar as the therapist transforms his implicit emotional memories of past experiences into explicit memories of emotional experiences, he acquires an adequate regulation of his emotional responses. Lastly, how this evolution may be traced considering the genogram of the therapist's family of origin, and its progressive modifications during the training, as a parameter of his personal and professional development.

Introduction.

The specificity of the systemic family therapist's training consists in the acquisition of a systemic way of thinking, which enables him to operate by using the logic of circular causality, to articulate the different levels of complexity among individuals, relationships between individuals, systems of relations and interacting systems.

However, the access to circular causality implies exploring the vicissitudes of recursivity and self-reference, which place the therapist in a paradoxical situation since, as described by Heinz von Foerster, the founder of second-order cybernetics, he becomes an observer that orders and organizes a world that is built from his own experiences. As it is not possible to access an objective reality, because the properties of the observer determine the characteristics of what is observed, the question arises of how we know what we know. Humberto Maturana, in his theory of knowledge, proposes the concept of structural coupling as a way of interaction or intersection between a system - a living system, a knowledge system, etc. - and its environment, which, with its disturbances, produces in the system the structural changes that its organization enables him to assimilate.

Mony Elkaim introduces these concepts - self-referentiality and structural coupling - in the field of family therapy and creates with the concept of "resonance" a unique bridge, not only between systemic epistemology and family therapy, but also between the therapist and the members of a family system. The concept of resonance defines phenomena of a different order: one concerning the amplification of similar elements that are also common to the various interacting systems; said amplification emerges in the possible intersection between their structures or constructions of the world; the other one concerning the function acquired by such amplification in respect of all of these structures or constructions of the world.

Thanks to the concept of resonance, the self-referential paradox ceases to be a limit and becomes a possibility, *if, and only if* the therapist has learned to use himself as a therapeutical instrument: if he knows how to use the systemic function of resonance to generate new possibilities for the therapeutic system, i.e. if he has learned how to use the emotions and perceptions that the system evokes and/or amplifies from his own family history, so as to prevent the constructions of the world of members of the family system and his own constructions from strengthening each other.

To attain this objective, the therapist must go through a process of cognitive and emotional learning. From the cognitive point of view, he must progressively acquire new levels of complexity in his thinking: setting out from a linear causal logic, which enables him to read only individuals, to access relational readings - relationships between individuals - and, from circular recursive dyadic and triadic interactions, intuitively perceiving the emerging properties of a system. Only by rising to

¹ Child Psychiatrist, Family Therapist, Rome, Italy.

these levels of complexity and abstraction in his thinking can the therapist understand, in my opinion, the significance of the inter-systemic nature of resonance. But above all he should acquire, from an emotional point of view, an adequate regulation of his emotions: he must learn to work in the intersection between that which constitutes him from the past - his family history - and the present context - the therapeutic system - without being invaded by the emotions or perceptions that the therapeutic system evokes and/or amplifies - as an effect of resonance - of his own history. For this purpose, the therapist should acquire an emotional learning that necessarily depends of the recognition of his own family history.

This learning, acquired during the training in the form of an appropriation process of the therapist's family history, will be the central subject in this article.

For the purpose of evidence this appropriation process I will expose, firstly, two examples of indirect supervisions to demonstrate how, from some structural similarities between the consulting family and the therapist's family of origin, the latter² recovers significant aspects of his family history.

Secondly, I will describe the characteristics of the appropriation process of the therapist's family history, considering the indirect supervision as a learning context and proposing some neurobiological mechanisms that contribute to the emotional learning.

Lastly, I will describe the evolution of two other therapists, considering as a parameter of their personal and professional development the progressive modifications occurring in the genograms of their families of origin during the quadriennial formation period.

1. First and second situation of indirect supervision

a) First situation.

The therapist meets a very depressed patient who, crying, relates that her marriage is in a crisis, that she cannot cope with her three children and feels very much alone since her parents died, one shortly before and the other shortly after the birth of her third child.

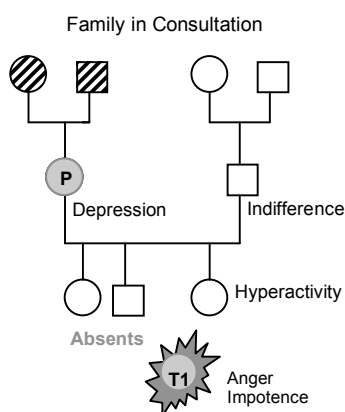

The therapist then decides to convene all the patient's family, but only her husband and her youngest daughter come to the appointment; the two elder children are absent. During the meeting, the therapist does not know how to control the youngest girl's hyperactivity and besides, the husband's indifference and the absence of the other two children causes her a growing anger. Feeling blocked and incapable of giving any help, the therapist tell the patient that in effect, in her family she is alone and advises her to initiate individual psychotherapy with another therapist.

Subsequently, the therapist asks for indirect supervision to understand the reason for her reaction.

During the supervision some significant data arise on the therapist's family history: her family of origin is comprised of her mother, her father, two elder sisters and herself, the youngest. Shortly before her teens, her father's company goes bankrupt and the family was precipitated into economic collapse. The two elder sisters marry, one after the other and leave her alone, with a father who is destroyed by economic failure and a mother who devotes herself exclusively to the moral support of her depressed husband. Unable to ask any help for

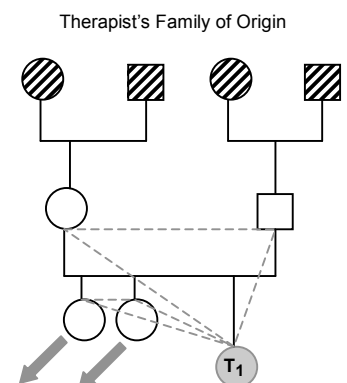

² Therapists at the beginning of their training.

herself, lest her parent's situation should worsen, the therapist turns to the outside world by increasing her social activities and studies.

A structural analysis of relational configurations evidenced the existence of two triangles in the therapist's relationship with her parents and with her sisters, and in both cases the therapist was in the position of the third excluded. From this position of exclusion, she perceived her mother as distant and indifferent to her troubles, her father as inaccessible in his depression and the absence of her sisters, at such a dramatic time for the family, as a betrayal and an abandonment.

Supervision work enables the therapist to confront the characteristics of both family systems and verify some structural similarities, from which she can begin to understand the possible meaning of

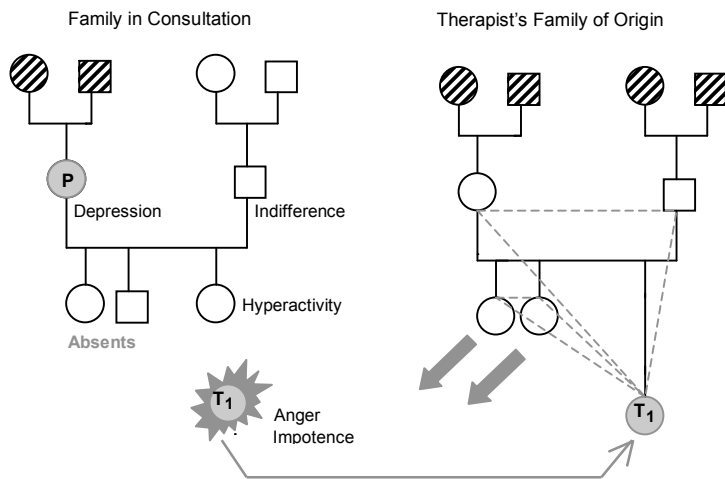

her reaction that is, how the encounter with the consulting family had evoked and amplified elements pertaining to her family history. From these data, the therapist can attribute her reaction of anger and impotence to the feeling of loneliness and exclusion she had lived through, in her family relationships. In the process of recognizing that experience and taking it back to the original relational configurations she can recover significant aspects of her family history that had not previously been identified as such.

b) Second situation.

The therapist meets a young woman who consults because of her phobic- obsessive symptoms. Despite having suffered these symptoms for the last 7 years, she is consulting now because she has married and has become pregnant; then she fears her obsessive thoughts may prevent her from attending to the baby's needs. The patient comes to the first interview with her sister, the second time with her mother. When the therapist asks her to come with her husband, she come with her sister, her mother and her husband.

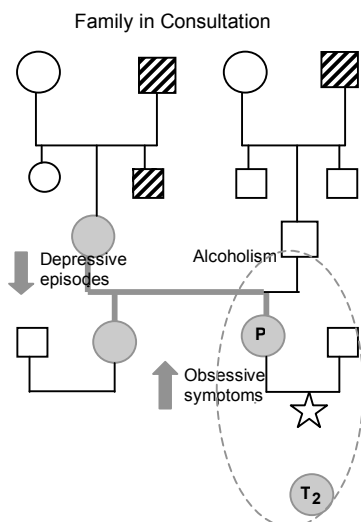

The therapist request supervision because she doubts about the most adequate therapeutic context to care for the newborn child: individual therapy for the patient or therapy for the couple?

During the supervision, a more exhaustive analysis of the consulting family reveals important clinical data unnoticed by the therapist before:

- the alternating correspondence through the years, of the phobic- obsessive symptoms of the patient with her mother's depressive episodes,
- the contrast between the intense bond that connects the family's women and the problematic presence and/or absence of most of the family's men.

As both are cases of indirect supervision, it is the therapist who describes the characteristics of the consulting family and the characteristics of his family of origin.

In both cases, the meeting with the family in consultation evokes and amplifies elements pertaining to the therapist's family history; the therapist not knowing how to recognize what constitutes him cannot avoid being invaded by the intensity of his emotional reaction - rage or anguish- which disorients and paralyzes him to the point that he has to ask for supervision.

In both cases, from certain structural similarities or isomorphisms³ between the family systems, the therapist recognizes what has been evoked and amplified from his past, and taking it back to the original relational configurations, recovers significant aspects of his family history. This process of appropriation of the experience lived through in his family of origin, entails a cognitive learning - the access to a relational, not yet systemic, thinking - and an emotional learning - the access to an adequate regulation of his emotions - that reorganizes in the therapist the perception of himself and of his relationship with his family members.

A further common element in supervision work concerns the managing of similarities and differences: from the similarities between both systems, insofar as the therapist recognizes the constituent elements of his past, he succeeds in recognizing the differences in the present context of the therapeutical system. If the capacity to recognize the differences depends on the possibility to recognize the similarities, it means that the therapist's possibility to acquire an adequate regulation of his emotions - in such a way as to prevent the world constructions of all the members of the therapeutical system to mutually reinforce each other - when working in the intersection between past and present, *necessarily depends* on the degree of appropriation of his family history.

In the first supervision situation, it is by starting from the recognition of her own experience of loneliness and exclusion inside her family of origin, that the therapist may realize how her reaction of impotent anger, and her recommendation of individual therapy for the patient, strengthened the conviction of all the members of the therapeutic system - including herself - about the impossibility to receive help within one's own family.

In the second supervision situation, it is from the recognition of her own need to isolate conflictive links within her family - nuclear family and family of origin - , that the therapist may realize how she may have strengthened, in all members of the therapeutic system - including herself - the perception of irreconcilability between significant affective links.

b) Neurobiological foundations of cognitive and emotional learning.

Joseph LeDoux (2005) believes that, for memories of emotional experiences, the brain uses two different learning systems or two types of memory: one is implied in the formation of conscious recollections of emotional experiences, it constitutes the declarative or explicit memory and the memories thus created may be evoked and described verbally. The other system of learning or type of memory is implied in the formation of implicit emotional memories, it constitutes the implicit memory and the memories thus created govern behaviour without explicit awareness of past learning.

For LeDoux (1992):

- an emotion may be a way of remembering: “ Affective memories - emotions - can be but are not necessarily memories in the sense of conscious recollections. However, they are memories in the sense that they represent information storage in the nervous system and in the sense that they can have powerful influences on future information processing and behaviour”, and,
- a memory must be activated by a stimulus: “Memories are stored in the form of associative networks, cognitive structures where the different components of the recollection are presented separately and connectedly. For a recollection to be aroused in one's memory, this associative

³ I consider isomorphisms - structural similitudes - as a form of resonance, that is, as the amplification of structural elements - relational configurations - similar and common to the different interacting systems.

network must reach a certain level of activation, which takes place depending on the number of components of the activated recollection and their respective degree of contribution”.

On the basis of these data, we could consider the emotional responses of the therapists - the anger of the first and the anguish of the second- as an affective memory; in other words, as information stored in the nervous system, in the form of an associative network which contains the implicit emotional memory of a past experience. We could also hypothesize, that the stimulus represented by the structural elements that are similar in both family systems might have activated certain components of the associative network that constitute the affective memory, thus provoking in the therapists the emotional reactions corresponding to that affective memory.

In the case of the first therapist, the stimulus that activates the affective memory could have been, for instance, the emotional distance between the members of the family, existing in both family systems, that emerges successively in the context of supervision in the form of isomorphism. In the case of the second therapist, the stimulus that activates the affective memory could have been, for instance, the perception of incompatibility between significant relationships, existing in both family systems, that emerge successively in the context of supervision in the form of isomorphism.

LeDoux (2005) also considers that the brain may evaluate a stimulus in an incomplete way: “The emotional significance of a stimulus may begin to be evaluated before the perception systems have processed it completely. In fact, it is possible for our brain to know whether something is good or bad, before knowing exactly what it is about”.

From the study of a specific emotion, fear and its various manifestations, LeDoux proposes a triangular neural model which connects the amygdala - responsible for the evaluation of the emotional significance of a stimulus and its memorization in the form of implicit emotional responses -, the thalamus - responsible for the subcortical elaboration of sensorial stimuli -, and the sensorial cortex - responsible for the conscious elaboration of emotions -, into a nervous circuit which implies a parallel transmission of signals from the thalamus and the sensorial cortex to the amygdala. The subcortical way provides a simple, inaccurate image of the external world, whereas the more detailed, complex representations come from the cortex:

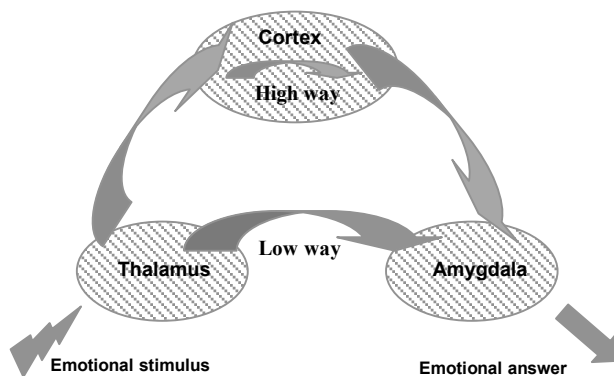

“The information about the external stimuli gets to the amygdala through a direct way from the thalamus - low way- or through another way that crosses the cortex. The low way is shorter and therefore quicker than the one coming from the cortex. But, as it shortcuts the cortex, it cannot benefit from cortical treatment and can give the amygdala only a rough representation of the stimulus. It is a quick, rough kind of treatment. This direct way enables us to begin to respond to potentially dangerous stimuli before knowing exactly what they are about. This direct way could also be involved in the emotional responses that we do not

understand”.

The existence of this twofold way of processing information could ultimately explain why, in the encounter with the consulting family, the therapists are invaded by their emotions: when the stimulus represented by the elements that are similar in both family systems activates certain components of the associative network that constitute the affective memory, the amygdala, recognizing the emotional significance of the stimulus as “similar to”, *assimilates* the experience in the present to the implicit emotional memory from the past experience. Thus, before knowing exactly what it is about, evaluates it as “more bad than good” and unleashes the adequate emotional response: in this case, anger or anguish.

In other words, the absence of recognition, at a cortical level, of the evaluation made, at subcortical level, of the emotional meaning of the stimulus (evaluated according to the implicit emotional memory of a past experience) does not permit the therapists to distinguish the existing differences, at cortical level, between both family systems. These differences have been assimilated, at subcortical level, in the equivalence between the experience in the present and the implicit emotional memory of a past experience. The therapists are therefore invaded by their own emotions, owing to the intensity and abruptness of the emotional reaction unleashed by the amygdala, and owing to the absence of an explicit and conscious cortical treatment of the information.

LeDoux holds that “The emotional memories of the amygdala are deeply ingrained in its circuits. The best we can do is regulate their expression...and we do that by giving more power to the cortex over the amygdala...Helping the cortex to have more control over the amygdala...could imply the regulation of the amygdala by the explicit knowledge of the memory system...and of other cortical areas participating in becoming aware. It is interesting that the connections of cortical areas to the amygdala are known to be weaker than those going in the opposite direction. That may explain why emotional information can so easily invade our conscious thoughts and, conversely, why it is so difficult for us to acquire a conscious control over our emotions”.

Reconnecting the brain implies that the cortex should “learn” to recognize what the amygdala evaluates, and that the amygdala should “learn” to discriminate what the cortex distinguishes.

The emotional learning displayed during the training through a process of appropriation of the therapist’s family history, transforms his implicit emotional memories of past experiences in explicit memories of emotional experiences. This transformation implies a regulation of the affective memories - emotions- of the amygdala, thanks to the explicit knowledge of the declarative memory system.

3. The process of appropriation of the therapist’s family history as a parameter of his personal and professional evolution.

I will present the evolution of two therapists during their quadriennial formation period.

I will use the genograms of their respective families of origin and the progressive modifications of the genograms during the direct and indirect supervisions, so as to evidence the characteristics of the appropriation process of the family histories of both therapists. As they transform their implicit emotional memories of past experiences into explicit memories of emotional experiences, the therapists recover important elements of their family history and identify new relational configurations in their families of origin that reorganize their perception of themselves and their relation with family members.

a) First therapist.

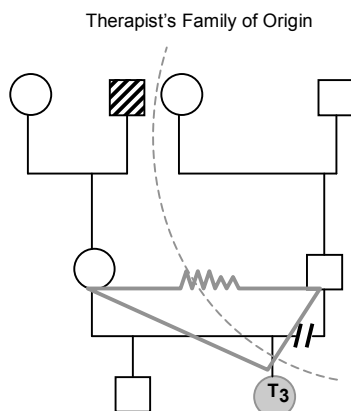

At the beginning of the training period, the therapist exposes the genogram of her family of origin, on the basis of the data she considers most significant:

- at age 6, her parents separate,
- the mother returns to her parent’s home and the therapist and her brother are raised by the maternal grand parents, thus losing all contact with their father and paternal grand parents,
- at age 10, the maternal grand parent dies,

- the therapist remembers her parent's separation and feeling torn between the constant conjugal conflicts, as the most important event in her family history.

Further on during the training period, the therapist treats a patient with an addiction problem in the context of a therapeutic community. As the patient's mental disorganisation does not allow her to

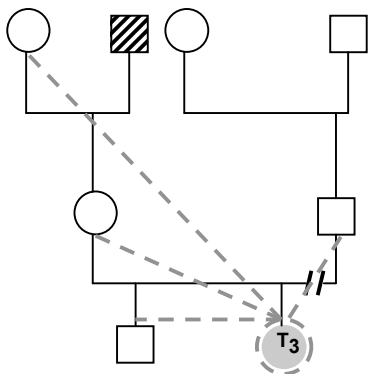

reconstruct his symptomatic history, she decides to convene his family. They not only fail to contribute any kind of explanation, but disorient her even further. The therapist request indirect supervision because she feels, with respect to her patient, like “standing on the void”. During supervision the therapist revises the relationships in her family of origin and recovers the way in which she had build up her conviction of great autonomy and independence from relational experiences of emptiness and confusion: *“I have always wanted to be and show myself before others as independent. In my effort to prove that I was capable of doing everything on my own, without asking for anything from anyone, I did not realize my own loneliness. I believed myself independent*

when really I did nothing more than depend from the image I wanted to give of myself to the family. I confused not having anything to ask for with not having anyone to ask”.

During advanced training, the therapist submits the case of a transgressor teen-age girl she follows under therapy with her mother. She request indirect supervision because she does not know how to set a limit to and maintain intergenerational hierarchy between mother and daughter.

During supervision she again revises her family of origin and recovers the triadic dynamics in the

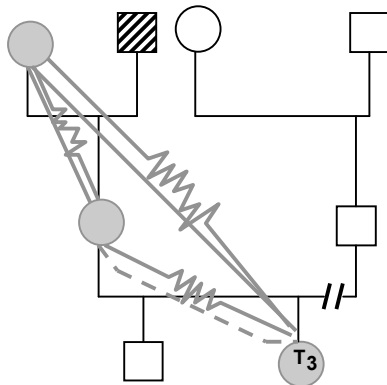

grandmother- mother- daughter family interactions, which enables her to understand the reason for her confusion and her own difficulty in setting boundaries: *“I think I have been the daughter given as a gift from my mother to her mother, with the duty to perform what herself didn't fulfil. My grandmother used to despised my mother, nothing that she did was right, even if my mother did all she could to please her. My mother was always for me the daughter of my grandmother, rather like a sister that my grandmother mistreated and I often had to defend...but my mother was jealous of my relationship with my grandmother, even though my grandmother kept reminding me that to be loved, I had to do everything right”.*

Towards the end of the training period, the therapist starts, this time in the context of direct supervision, the therapy for a family whose only son shows psychotic symptoms. The relational configuration is characterized by conjugal conflict, an invasive mother and an absent father who, shortly before the birth of his son, broke up his relation with his own father.

Limiting maternal invasiveness and involving the father as such, setting out from his relationship as

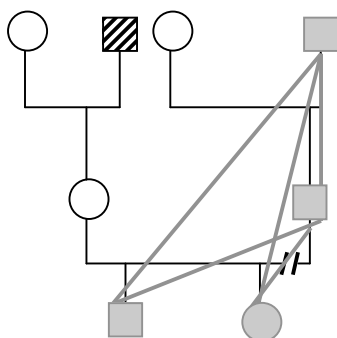

a son with his own father, are the two therapeutic objectives agreed between the supervisor and the therapist, who manages to achieve the first one, but becomes paralysed when facing the second.

Supervision work enables the therapist to revise, in spite of her fear, the circumstances that caused her parent's separation and particularly, the fundamental role of her grandmother's invasion in the couple's conflicts and the gradual estrangement of her father. As from this work and after over 20 years, the therapist resumed contact with her father and understood, though his own family history, the reasons why he had not been able to assert his rights to parenthood.

In this evolution, every time the therapist performs a supervision task, there is a recognition of the history lived through, which brings about an appropriation of her family history: insofar as she transforms the implicit emotional memories of past experiences into explicit memories of emotional experiences, she recovers important elements of her family history and identifies new relational

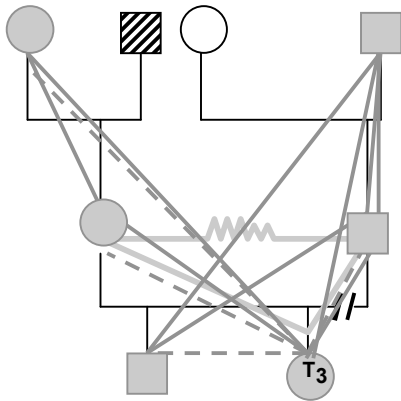

configurations that reorganize the perception of herself and her relationship with the other family members. Along this way, the process of appropriation of her family history allows for an emotional learning, since the transformation of implicit memories into explicit memories brings about, every time, a regulation of affective memories - emotions - of the amygdala, thanks to the explicit knowledge of the declarative memory.

Successive structural modifications in the genogram of her family of origin constitute the indicators that enable us to follow this evolution along the formation period and which bear witness to the process of appropriation of the therapist's family history.

b) Second therapist.

At the beginning of the training period, the therapist exposes the genogram of her family of origin, on the basis of the data she considers most significant:

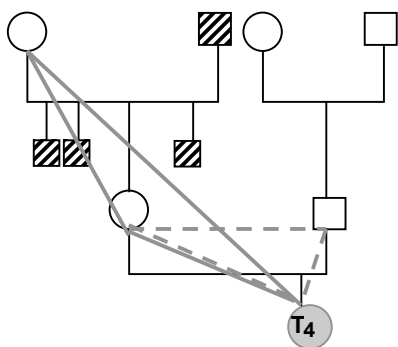

- her mother's family of origin suffers the loss of 4 members to tumour diseases,
- the therapist's mother is more present in her own family of origin than in her nuclear family; for this reason the therapist's parents are in constant conflict,
- the most important perception referred by the therapist is feeling "trapped" in the conflictive relationship between her father and her mother, and in the dependence relationship between her mother and her grandmother.

Further on during the training, the therapist submits the case of a family that she follows in a hospital. The patient ("M") is a teen-age girl, paralysed by a neurological tumour; the brother has died recently from a similar tumour and the family has decided to adopt the rule of silence for the patient, that is, to keep her diagnosis secret. The therapist request indirect supervision because she feels impotent, trapped between the service that delegates on her the psychological treatment of the patient, and the patient's family who refuse any help that implies revealing the secret.

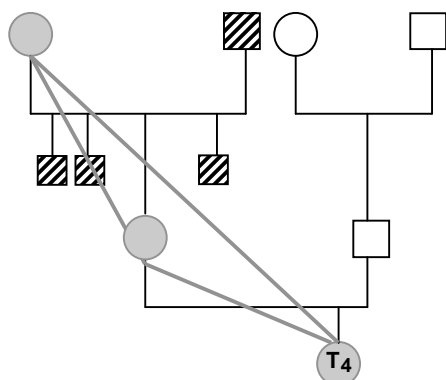

During supervision the therapist revises the history of non-elaborated mourning in her mother's family of origin, identifies the homeostatic function of silence in keeping relationships of dependence between mother and daughter and intuitively finds, in her own difficulty to detach herself, the probable origin of her perception of impotence: *"My family, like "M" 's family, has suffered important losses. Death has pervaded family relations and loved ones have disappeared one after the other without a trace, since none of us can, nor wishes to name their absence. Dead souls do not permit separation in my family;*

neither my mother from her mother, nor me from both, because separating involves a loss that is impossible to elaborate. The history of "M" had in my life the effect of a stone thrown into a stagnant pool, causing a thousand ripples and a deafening noise, breaking every human and professional barrier I could have erected".

Towards the end of the training period, the therapist initiates, in the context of direct supervision, the treatment of a family whose parents consult because they are unable to establish rules for the education of their three small children. The two elder children suffer from haemophilia, the second one is also enuretic and all three of them have behaviour problems. The chaotic sessions transforms the supervision context in a supervisor- therapist co-therapy, facing a family characterized by "incontinence", where parents participate, demanding results on one hand while invalidating therapeutic interventions on the other.

During supervision, the therapist expresses her wish to withdraw from the case: she feels frustrated before a family where, in each session, it is necessary to start all over again, and she feels blocked between the requests from the supervisor and the family's reticence.

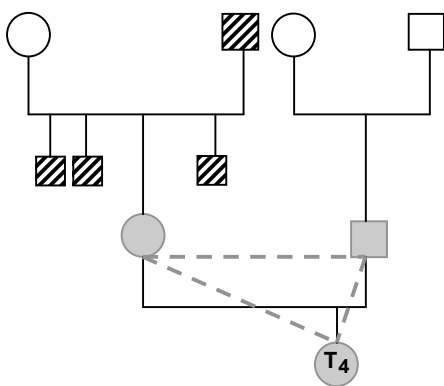

The therapist again revises her family relationships, particularly with her parents, and comes to realize how she participates in keeping her own immobility, in the relationship between her mother and her father: "I have always felt, in my life as a daughter, that I had little space, because my parents gave me little space and because I never thought that I could do something to take my own place"; and in the clinical context between the family and the supervisor: "I felt invisible and at the same time perceived the risks of visibility... my difficulty to be in the experience has enabled me not to enter the experience".

This evolution evidences how, despite the different encounters with the consulting families and the respective supervisions, the therapist's perception of herself and of her relationship with others - in other words, always feeling "trapped in between"- is not modified. The encounters with clinical situations and with supervisions seem rather to reinforce the therapist's immobility and her conviction about the impossibility to act upon events. In this case, the particular gravity and complexity of the clinical situations found, could have increased the therapist's fear of modifying her personal and relational balance, thus generating specific difficulties in her cognitive and emotional learning: even though the therapist recovers some significant events of her family history, transforming implicit emotional memories of past experiences into explicit memories of emotional experiences, this recognition is still insufficient to acquire an adequate regulation of affective memories - emotions - of the amygdala, thanks to the explicit knowledge of the declarative memory

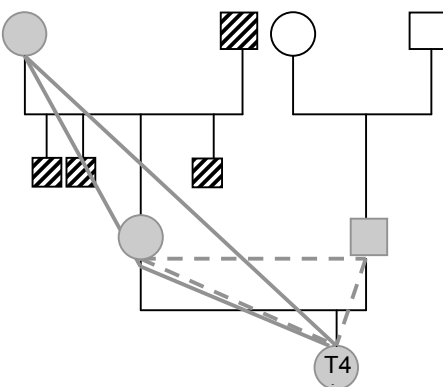

or, as LeDoux holds, to "help the cortex to have more control on the emotional memories that are indelibly buried in the circuits of the amygdala".

Along this way, the absence of structural modifications in the genogram of the therapist's family of origin evidences the lack of evolution in her personal and professional development: even if the process of appropriation of her family history may be considered as having started, it is still insufficient for the purpose of activating a reorganisation of the perception of herself and her relationship with others, a perception which, in fact, begins to modify itself only towards the end of the formation period.

Conclusion.

The therapist is his own main therapeutical instrument.

As an observer that orders and organizes a world build from by his own experiences, he must learn to use himself in a systemic way in the paradox of self- referentiality; he must learn to use his emotions and perceptions as indicators of the intersection between what constitutes him from his past - his family history- and the present context of the therapeutical system.

In order not to be invaded by the emotions that the therapeutical system evokes and amplifies from his family history, the therapist must go through a process of cognitive and emotional learning which necessarily depends on the recognition of his own family history.

In this paper I have tried to describe certain characteristics of the process of appropriation of the therapist's family history:

- how, in the context of supervisions and starting from structural similarities or isomorphisms between the consulting family and the therapist's family of origin, the latter recovers significant aspects of his family history,
- how, insofar as the therapist transforms his implicit emotional memories of past experiences into explicit memories of emotional experiences, he acquires control over his emotions. Therefore, instead of reacting, the therapist gains the freedom to decide how to act: acting always in such a way as to increase the number of alternatives was, for Heinz Von Foerster, an ethical imperative,
- how, finally, in each appropriation of the history he lived through, the therapist discovers new relational configurations in his family of origin, which reorganize his perception of himself and of his relationships with the other members. Also, how this evolution may be traced considering the genogram of the therapist's family of origin and its progressive modifications during the training, as a parameter of his personal and professional development.

Bibliography.

- Andolfi M., Angelo C., Tempo e Mito nella Psicoterapia Familiare, 1987, Ed. Boringhieri.
- Mony Elkaim; Si tu m'aimes ne m'aime pas, 1989, Editions du Seuil.
- LeDoux J., Le cerveau des emotions, 2005, Editions Odile Jacob.
- LeDoux J., Emotion as Memory : Anatomical systems underlying indelible neural traces, in The Handbook of Emotion and Memory: Research and Theory, 1992, edited by Sven-Ake Christianson.
- Von Foerster H., Ethics and second-order Cybernetics, 1990, Systems and Family Therapy International Conference.
- Maturana H., El Arbol del Conocimiento, 1984, Editorial Universitaria.